

DCC-9

Demand Charge Controller for Electric Vehicles

ENGLISH



DCC-9, manufactured by Thermolec, is an Energy Management System specially designed to allow the connection of an EV Charger to the main feeder of a panel without affecting the load calculation.

OPERATION

- Real-time reading of the total power consumption of a panel with pre-wired current transformers (CT).
- Detects when total power consumption exceeds 80% of main circuit breaker capacity and temporarily de-energizes the EV Charger.
- Automatically re-energize the EV Charger when the total power consumption is less than 80% of main circuit breaker capacity for more than 15 minutes.

FEATURES

- Ideal when no more breaker slots are available in a panel.
- Does not affect load calculation of a panel
- Automatic billing of electricity by the utility (for condo installations).
- Can be ceiling or wall mounted.
- NEMA 3R enclosure available for outdoor installations.

INCLUDED

- Charge Controller
- Splitter box (Max 125A)
- EV Charger Breaker (Max 60A)
- 2 pre-wired current transformers (CT)

Models	Breaker EV charger	Main power supply					
		60A	70A	80A	90A	100A	125A
DCC-9-30A	30A	✓	✓	✓	✓	✓	✓
DCC-9-40A	40A	✗	✗	✓	✓	✓	✓
DCC-9-50A	50A	✗	✗	✗	✗	✓	✓
DCC-9-60A	60A	✗	✗	✗	✗	✗	✓

Voltage and wiring	240/208V AC single phase: L1, L2, Neutral, Ground.
Terminals size	up to 2/0 (CU/AL)
Frequency	50 to 60 Hz
Operation temperature	-22°F to 113°F (-30°C to 45°C)

	Dimensions* (H" x W" x D")	Total weight*
	12" x 12" x 7.5"	17 lb (7,71 kg)
NEMA 3R enclosure	14" x 13" x 8"	18 lb (8,16 kg)

*Approximative and can change without notice.

V1

INSTALLATION EXAMPLES

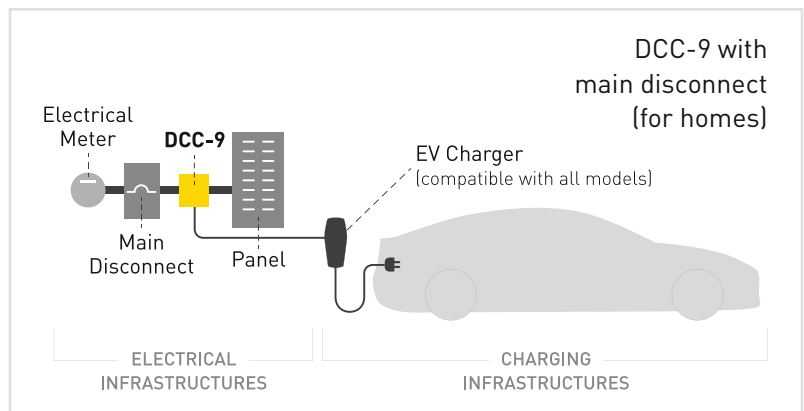
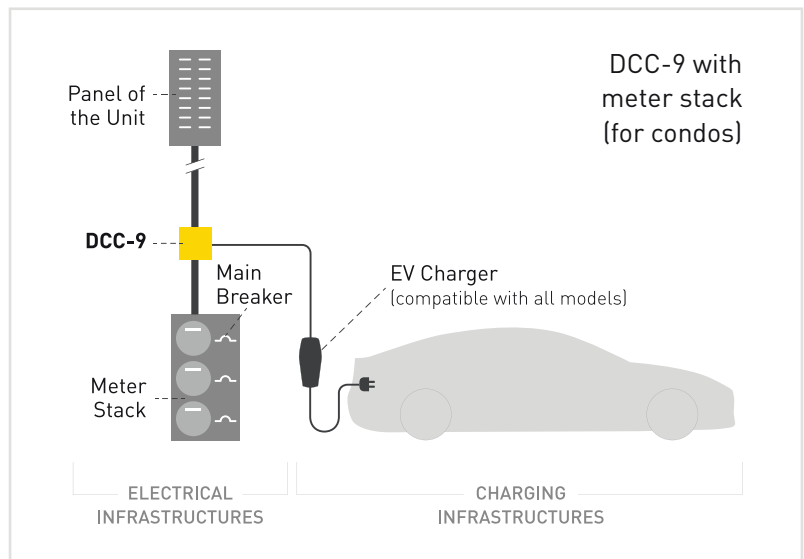

1-833-717-1355
www.dcc.technology



Splitter Box
120/240-208V (Max 125A)

Transformer,
Input: 240/208V, Output 24V

Main Power Lugs

Neutral Lugs

Main Load Lugs

Pre-wired Current
Transformers (CT) on L1 and L2

DIP switch configuration
for panel capacity

Contactor, 60 FLA, 50/60 Hz

EV Charger Breaker
(Max 60A)

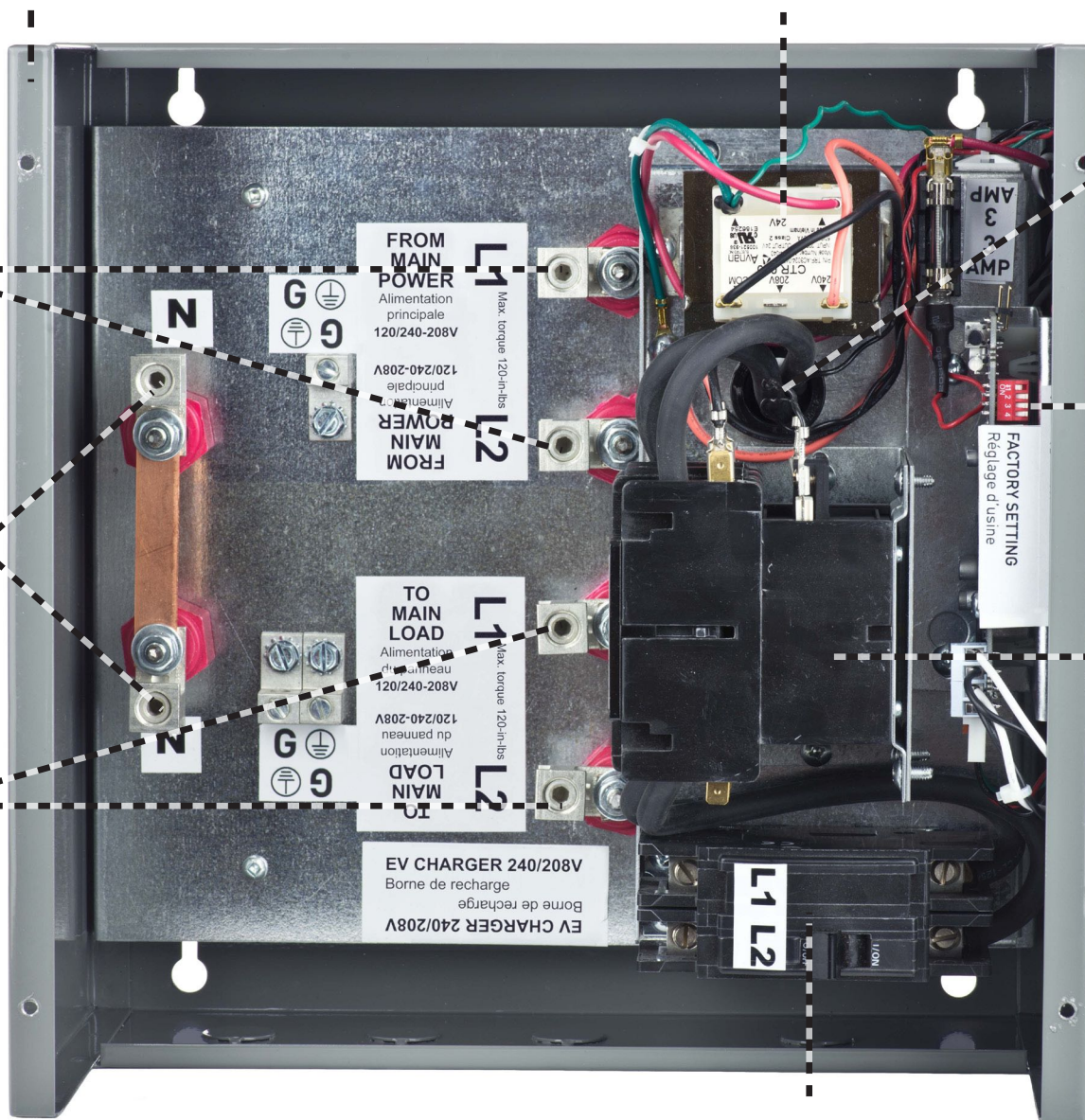

DCC-9

with

METER STACK

PANEL OF THE UNIT
120/240-208V, MAX 125A

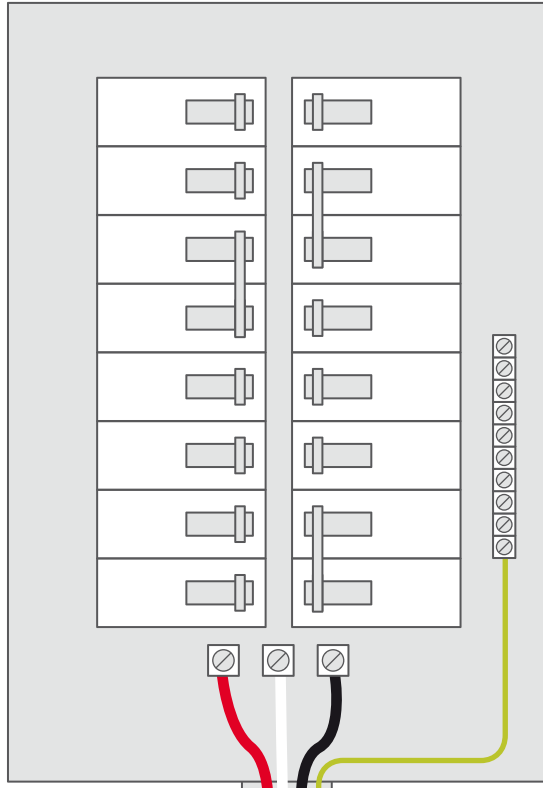

FEEDER OF THE UNIT

↑ **UPPER LEVEL**

METER STACK
120/240-208V

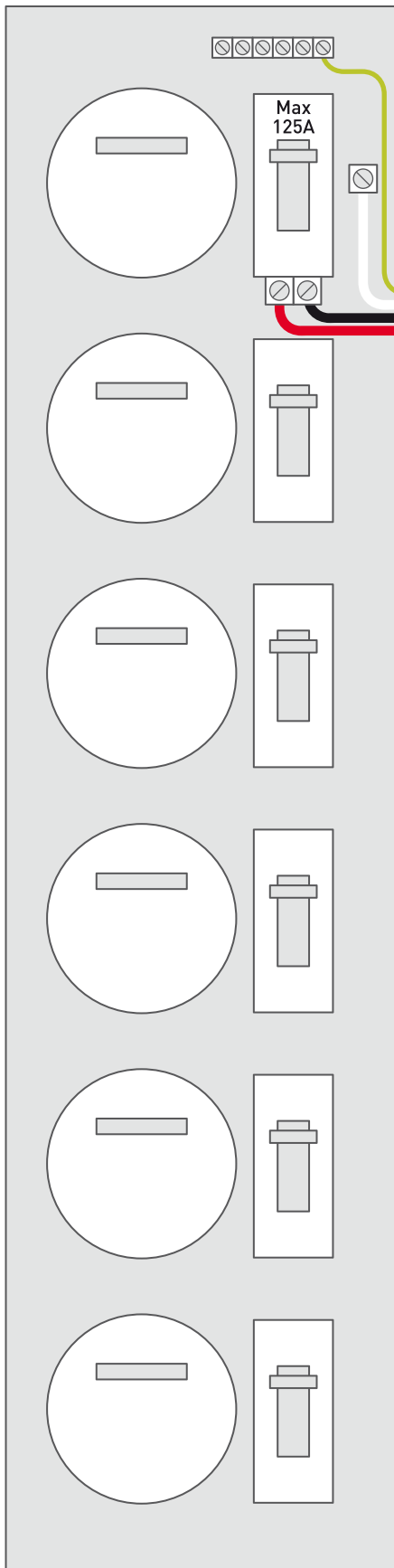

Pre-wired Current Transformers

DCC-9

CHARGE CONTROLLER, SPLITTER BOX 120/240-208V, MAX 125A

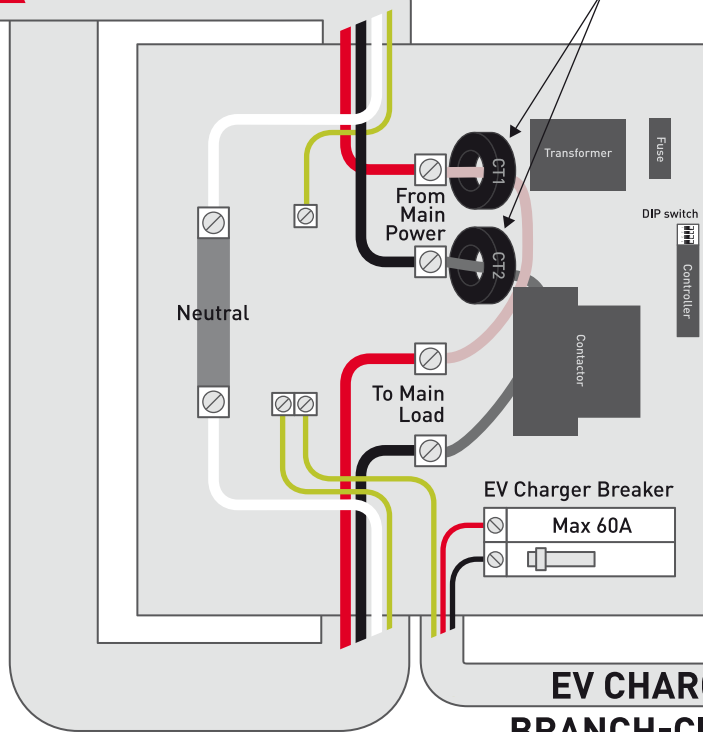

EV CHARGER BRANCH-CIRCUIT

